

# HIGH TIBIAL OSTEOTOMY PLATE



Surgical  
Technique



## Introduction

High Tibial Osteotomy Plate System: An adaptable plating system engineered to securely fix knee osteotomies, delivering both stability and dependability.

The HTO Plate System offers a comprehensive solution for the stable fixation of knee osteotomies, consisting of five distinct plates, each meticulously crafted for specific anatomical regions: The Medial High Tibia Plate, Medial High Tibia Plate (small), Lateral High Tibia Plate, Lateral Distal Femur Plate, and Medial Distal Femur Plate.

Adhering to the principles of the Angle Stable Locking Plate (ASLP®) System, the HTO Plate System features fixed-angle locking holes to ensure screws are securely retained in both the plate and cortical bone. Dynamic compression can be achieved by eccentrically inserting 4.5 mm titanium cortex screws into the dynamic compression unit section of the hole.

The HTO Plates are available in titanium and are offered in lengths ranging from 102 mm to 141 mm. They are compatible with 5.0 mm titanium locking screws and 4.5 mm titanium cortex screws, guaranteeing a reliable and sturdy fixation for knee osteotomies.

These plates are thoughtfully designed with anatomical contours, eliminating the need for intraoperative shaping and reducing irritation to the surrounding soft tissues. Their extended shaft provides robust support and effectively diverts forces in the diaphysis. Tapered ends on the plates facilitate sub muscular insertion. The inclusion of locking screws contributes to fixed-angle constructs, ensuring angular stability. Furthermore, spacers are employed to reduce contact between the plate and bone, which may aid in minimizing disruption to the periosteal blood supply.



## Indications

**High Tibial Osteotomy (HTO):** The primary use of the HTO Plates is in high tibial osteotomy procedures, aimed at addressing conditions such as knee osteoarthritis within the medial compartment, varus malalignment (bow-legged), and early-stage unicompartmental arthritis.

**Correction of Varus or Valgus Deformities:** The HTO Plates plays a crucial role in rectifying varus (bow-legged) or valgus (knock-kneed) deformities of the knee by realigning the weight-bearing axis of the lower limb.

**Management of Unicompartmental Knee Arthritis:** In cases where damage is limited to a single compartment of the knee (either medial or lateral), the HTO Plates can be employed to redistribute forces across the knee joint, alleviating stress on the affected compartment.

**Promoting Joint Preservation:** The HTO Plates contributes to joint preservation, allowing patients with early-stage knee arthritis to delay or potentially avoid the necessity for a total knee replacement (TKR) by providing a stable and enduring solution.

**Suitable for Young and Active Patients:** It is frequently recommended for younger and more active patients who may not be ideal candidates for total knee replacement due to their age or lifestyle.

**Realignment of the Knee Joint:** The HTO Plates facilitates the transfer of weight-bearing forces from the compromised or diseased portion of the knee to the healthier side, reducing discomfort and enhancing joint functionality.

**Management of Degenerative Joint Disease:** The HTO Plates is employed to address degenerative joint disease and offer pain relief to individuals who have not responded positively to conservative treatments.

**Osteoarthritis Treatment:** In cases of early-stage osteoarthritis, the HTO Plates is a viable option for managing pain and functional limitations while preserving the natural knee joint.



## Surgical Procedure ( HTO Medial Plate)

The HTO Plate (High Tibial Osteotomy Plate) boasts remarkable versatility. This plate incorporates three Combi holes (labeled 1, 2, and D) that enable axial compression and locking capabilities, providing a flexible approach to the surgical process. Furthermore, the plate is equipped with an additional five holes (labeled 3, 4, A, B, and C) designed explicitly to accommodate locking screws, ensuring a stable and secure fixation during the osteotomy procedure. The HTO Plates ensures precision and dependability for successful high tibial osteotomy surgeries.

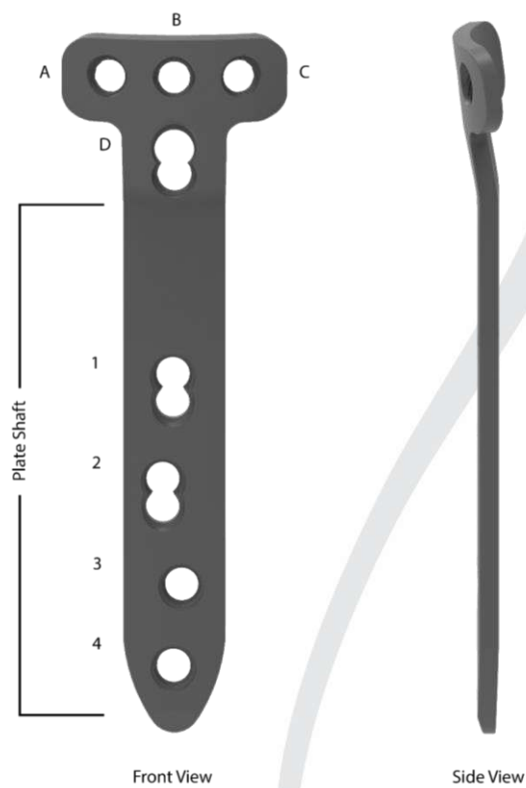



## Step 1: Position the HTO Medial Plate and attach the drill guides for the surgical procedure.

**Instruments:**

HTO Plate (ASLP-4.5/5.0 Medial High Tibia Osteotomy Plate-PT147.04, PT174.04)  
 Ø4.3 mm Drill Sleeve  
 (Instrument Code: TP245.33)

Insert the first 4.3 mm threaded ASLP Drill Guide into the central proximal plate hole marked as B (see Figure 1). Next, insert the remaining two 4.3 mm threaded ASLP Drill Guides into the adjacent proximal plate holes labelled as A and C.

Please be aware that these steps are an integral component of the surgical technique involving the utilization of the HTO Medial Plate and the specified instruments mentioned above. The HTO Medial Plate offers precision and guidance, facilitating the success of high tibial osteotomy surgeries.

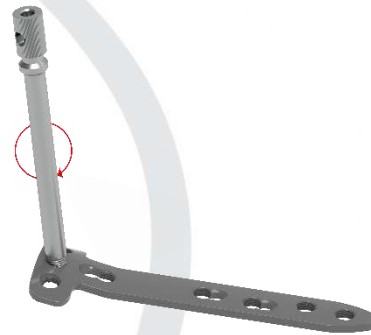

## Step 2: Position the HTO Medial Plate and attach the drill guides for the surgical procedure.

**Instruments:**

5.0 mm Titanium Spacer (Instrument code: ST233)

With precision, place the 5.0 mm titanium spacers into Combi hole D, aligning them with either locking hole 3 or locking hole 4, as indicated by the specific surgical case.

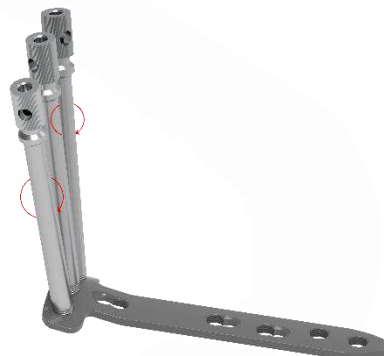



## Step 3: To determine the optimal osteotomy position

To determine the optimal osteotomy position, thoughtfully plan the type and location of the osteotomy utilizing the HTO Plate (ASLP-4.5/5.0 Medial High Tibia Osteotomy Plate). The HTO Medial Plate is suitable for both opening-wedge and closing-wedge osteotomies.

Designate the desired osteotomy position by positioning two parallel 2.5 mm Kirschner wires along the osteotomy plane. In the case of closing-wedge osteotomies, it is crucial to define both a proximal and a distal osteotomy plane to create a wedge. Ensure that the wires precisely terminate at the opposite cortex. Maintain approximately 15 mm of space before reaching the opposite cortex to preserve a bony hinge, a critical element for the subsequent steps. Employ fluoroscopic monitoring to validate the accurate insertion of the Kirschner wires.

The provided illustrations depict instances of opening-wedge osteotomies. Ensure that there is ample space for all plate screws when positioning the two wires.

## Step 4: Biplanar osteotomy

Conduct the biplanar osteotomy in accordance with the preoperative plan, utilizing the HTO Plate (High Tibial Osteotomy Plate). The Kirschner wires will serve as guides for the saw blade during the procedure.

Ensure that the transverse osteotomy traverses the posterior two-thirds of the bone while leaving the ventral third undisturbed. This configuration allows for a second, ascending osteotomy in the coronal plane (Biplanar technique).

Take precautions to safeguard anatomical structures located dorsally on the posterior bone surface, utilizing a Hohmann retractor. Progress through the sawing process deliberately, applying minimal pressure, and consistently cooling the saw blade with irrigation.

Upon reaching the planned depth in the posterior two-thirds of the bone, conscientiously execute the anterior ascending saw cut with a slender saw blade. This ascending cut should result in a complete osteotomy, including the opposite cortex.

Please be aware that post-osteotomy, it is essential to carefully close the osteotomy by applying continual pressure to the lateral lower limb while stabilizing the knee joint region in the case of closing-wedge osteotomies. Alternatively, you can follow the techniques described in the subsequent section for opening the osteotomy (Opening the Osteotomy). This procedure may require several minutes to complete.

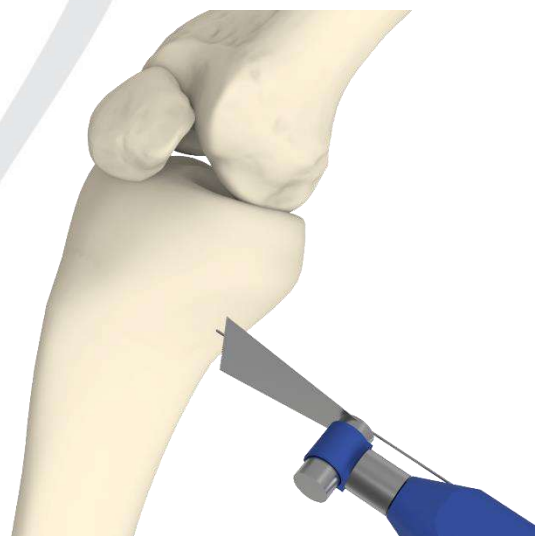



**Precautions:**

To maintain the tibial slope's inclination, it's crucial to ensure that the wires run at a consistent angle to the tibial plateau. It's of utmost importance to execute the ascending osteotomy cut parallel to the anterior cortex of the tibial shaft, resulting in an angle of approximately 110° to the transverse osteotomy cut. This is essential for achieving a robust bony connection in the region of the ascending cut after opening the osteotomy.

During the dissection process, exercise diligence to avoid harming the dermal branches of the saphenous nerve.

Exercise vigilance when handling neurovascular structures during the sawing procedure to prevent inadvertent intrusion into the posterior knee area. Utilize sharp saw blades at all times, as the use of a dull blade may induce heat necrosis in the bone and adjacent soft tissues.

In the case of performing a distal femur osteotomy, employ a blunt retractor to safeguard neurovascular structures, mitigating the risk of injury to these vital elements.

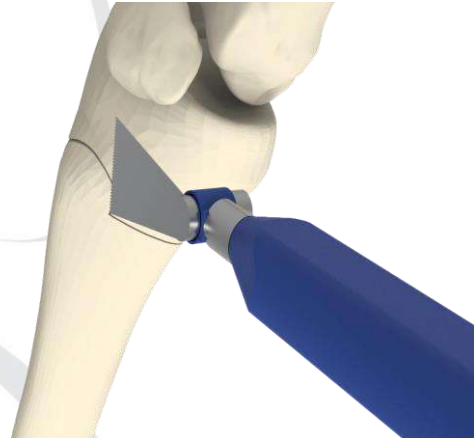

## Step 5: Opening The Osteotomy

After completing the osteotomy, proceed to open and fine-tune the correction using the HTO Plate (High Tibial Osteotomy Plate) along with either the Osteotomy Chisels or the Bone Spreader.

**Option A: HTO Chisels**

**Instruments:**

HTO Plate (ASLP-4.5/5.0 Medial High Tibia Osteotomy Plate)  
Osteotomy Chisel 10,15,20,25mm (Instrument Code: TP245.24, TP245.25, TP245.26, TP245.27)

Insert the Osteotomy Chisel into the osteotomy up to the lateral bone bridge, marking the insertion depth as the cutting depth on the first chisel. Carefully introduce a second chisel distal to the first chisel, maintaining a depth roughly 10 mm shallower. If necessary, proceed with additional chisels between the first two to gradually expand the osteotomy until the desired opening height is achieved. Take care to open the osteotomy gradually over several minutes to prevent potential fracturing of the lateral cortex.





## Step 5: Opening The Osteotomy

### Option B: HTO Bone Spreader

#### Instruments:

HTO Plate (ASLP-4.5/5.0 Medial High Tibia Osteotomy Plate)

SW 3.5 mm Shaft (Instrument code: TP245.35)

Osteotomy Angle Measuring Guide (Instrument code: TP245.44)

Alternatively, the Bone Spreader can be employed to open and gauge the osteotomy gap in degrees. Gently insert the spreader into the osteotomy site until the instrument's tip reaches the hinge point of the osteotomy. Utilize a 3.5 mm hexagonal screwdriver to open the bone spreader and the osteotomy. The osteotomy depth can be determined by reading the scale on the spreader blade. Once the desired correction is achieved, remove the Bone Spreader and insert the 8 mm adjustable bone spreader into the open wedge to maintain the correction.

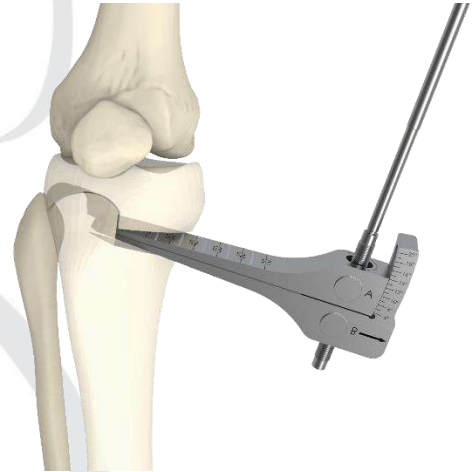

#### Note :

When opening the osteotomy, be cautious not to exert excessive pressure on the lateral hinge to prevent potential breakage.

These techniques ensure precise and controlled opening of the osteotomy, allowing for accurate correction and alignment with the HTO Medial Plate.

To ensure precise measurement of the open wedge height in millimeters, the HTO Medial Plate provides the option of using the Osteotomy Gap Measuring Device, which replaces the Osteotomy Angle Measuring Device.

Insert the Osteotomy Gap Measuring Device into the open wedge until it securely grips. Slide the measuring device towards the gap, ensuring the slider reaches the nearby cortex. The height of the open wedge can be accurately determined in millimeters by referencing the device's scale.



#### Precautions:

For control and fine-tuning of the osteotomy, always maintain the leg in full extension. Continuously monitor the osteotomy using the image intensifier in two planes. Pay close attention to the tibial slope for any potential alterations and be mindful of avoiding malrotation, as well as medial and lateral destabilization. These precautions are essential to preserving the desired correction and alignment throughout the surgical procedure involving the HTO Medial Plate.



## Step 6: To determine the ideal position for the HTO Medial Plate

To determine the ideal position for the HTO Plate (ASLP-4.5/5.0 Medial High Tibia Osteotomy Plate), ensure its centering over the osteotomy site where the 4.3 mm threaded ASLP Drill Guide(s) have been installed. Gently seat the plate onto the bone.

Ensure that the three holes in the head of the plate and the most proximal Combi hole on the shaft are situated proximal to the correction gap. The solid midsection of the plate should be accurately positioned over the osteotomy to provide stable support and alignment during the surgical procedure. Correct plate placement is paramount for achieving successful high tibial osteotomy outcomes with the HTO Medial Plate.



## Step 7: Affix the HTO Medial Plate securely to the bone

### Instruments:

- Ø4.3 mm Drill Bit (Instrument code: TP245.32)
- Ø4.0 N.m. Torque Limiting Screwdriver (Instrument code: TP245.48)
- Ø2.0 mm Guide Wire Sleeve (Instrument code: TP245.34)

### Important Note:

For control and fine-tuning of the osteotomy, always maintain the leg in full extension. Continuously monitor the osteotomy using the image intensifier in two planes. Pay close attention to the tibial slope for any potential alterations and be mindful of avoiding malrotation, as well as medial and lateral destabilization. These precautions are essential to preserving the desired correction and alignment throughout the surgical procedure involving the HTO Medial Plate.

Initiate by establishing a secure temporary fixation of the plate. Insert the 2.0 mm Guide Sleeve into the middle threaded 4.3 mm ASLP Drill Guide and introduce a Kirschner wire. This wire facilitates proper screw alignment parallel to the articular surface and allows for confirmation of screw position via radiographic imaging.

Utilize the calibrated 4.3 mm drill bit to determine the appropriate screw lengths for holes A, B, and C. For optimal support of the tibia plateau, employ the longest feasible fixed-angle self-tapping locking screws.

**Important Note:** The calibrated drill bit measurement is observed at the bottom of the slider, closest to the drill guide.





**Precautions:**

Take care to prevent plate rotation while unscrewing the drill sleeves.

To ensure the secure attachment of locking head screws and reduce the risk of the screw head cold welding to the plate, manually tighten the locking head screws using a torque limiter.

Following these precautions and procedures ensures the secure fixation of the HTO Medial Plate, contributing to the favorable outcome of the high tibial osteotomy procedure.



## Step 8: Insert screws into holes 1, 2, 3, 4, and D

**Instruments:**

SW3.5 mm Shaft (Instrument code: TP245.35)  
4.5/5.0 Universal Drill Sleeve with 4.3mm Drill bit (Instrument code: TP245.38)

The Combi holes in the HTO Medial Plate allow for the use of a lag screw, facilitating indirect reduction of the dislocated shaft and compression of fractures. Start by inserting a lag screw into hole 1. Spacers play a critical role in maintaining an adequate distance between the plate and the periosteum, minimizing harm to the blood supply and allowing the pes anserinus to move freely beneath the plate.

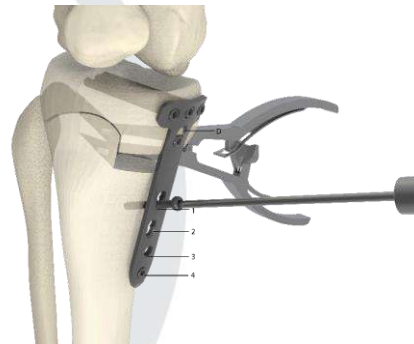

**Precautions:**

Continuously monitor for potential correction loss and ensure proper ventral bone contact of the ascending osteotomy. If necessary, make final adjustments to attain the desired alignment while avoiding excessive compression of soft tissue during the process.

The cortex screw should be slightly angled toward the distal aspect to prevent interference with the trajectory of the bicortical locking screw, which will be used in subsequent steps. Exercise special care when tightening the cortex screw to prevent thread stripping and associated bone damage.

To secure the shaft portion of the plate to the tibia, insert unicortical self-drilling locking screws into holes 2 and 3. Replace the lag screw in hole 1 with a bicortical self-tapping locking screw. Remove the spacer from hole 4 and replace it with a unicortical self-drilling locking screw.

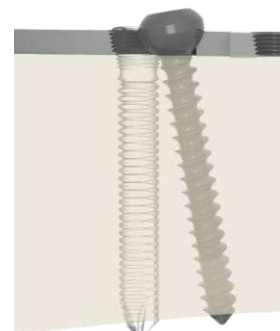
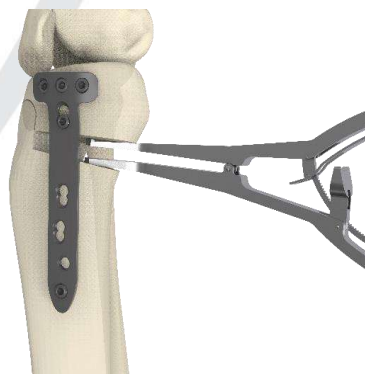

**Important Note:**

To prepare for the insertion of locking screws, place the self-retaining 3.5 mm hexagonal screwdriver shaft into the 3.5 mm hex recess of the 5.0 mm/4.5 mm ASLP Universal Drill Sleeve. Position the integral 4.3 mm drill bit accurately within the locking hole to ensure a proper engagement of the fixed-angle, self-drilling locking screws.

Following these steps with the HTO Medial Plate guarantees a secure fixation and precise alignment during the high tibial osteotomy procedure.

For the final step of securing the HTO Plate (ASLP-4.5/5.0 Medial High Tibia Osteotomy Plate) in place, substitute the spacer in hole D with a self-tapping locking screw of an adequate length that suits the patient's individual anatomy.

**Important Precaution:** Avoid utilizing power tools to tighten the screws, as their maximum torque surpasses the recommended limit. Complete screw tightening with power tools may result in damage. Instead, consistently employ the self-retaining 3.5 mm torque limiting screwdriver for the final tightening process. Verify that the screwdriver is properly seated in the screwhead to prevent harm to the hexagonal recess of the screw.

**Precaution:**

When finally seating all locking screws, employ the 3.5 mm torque limiting screwdriver with a torque limit of 4 Nm. Do not fully insert any locking screw using power tools.

By adhering to these precautions and leveraging the HTO Medial Plate, along with the appropriate instrumentation, you ensure the dependable fixation of the high tibial osteotomy, providing the necessary stability and alignment for a successful surgical outcome.





## Surgical Procedure (Lateral HTO Plate - ASLP-4.5/5.0 Lateral High Tibia Osteotomy Plate)

The HTO Lateral Plate represents a state-of-the-art surgical implant designed for lateral high tibia osteotomy procedures. It offers an innovative alternative to traditional plates, incorporating numerous advanced features aimed at optimizing surgical outcomes and expediting patient recovery.

Key Features of the HTO Lateral Plate:

- **Versatile Screw Options:**

The HTO Lateral Plate brings enhanced versatility to screw selection. Hole E on the HTO Lateral Plate is engineered to accommodate either 4.5 mm titanium cortex screws or 5.0 mm locking head screws. This adaptability empowers the surgeon to choose the most suitable screw type, considering the patient's bone structure and surgical requirements.

- **Secure Locking Mechanism:**

The HTO Lateral Plate integrates specialized Holes A, B, C, and D, purposefully designed for the acceptance of fixed-angle 5.0 mm locking head screws. This advanced locking mechanism ensures steadfast and rigid fixation, promoting proper bone healing and minimizing the risk of implant-related complications.

- **Combi Holes for Optimal Flexibility:**

The HTO Lateral Plate features Combi holes (1, 2, and 3) along the shaft region. These Combi holes grant the surgeon two essential options during the procedure. They can be employed for axial compression to enhance bone stability or for fixed-angle locking, averting unwanted movements and enabling precise control over the osteotomy.

Crafted from high-quality materials and utilizing cutting-edge engineering, the HTO Lateral Plate guarantees dependability and strength throughout the surgical procedure. Surgeons can confidently adopt the HTO Lateral Plate as a superior alternative, leading to enhanced patient outcomes and facilitating the correction of varus or valgus deformities of the knee, ultimately improving joint function.

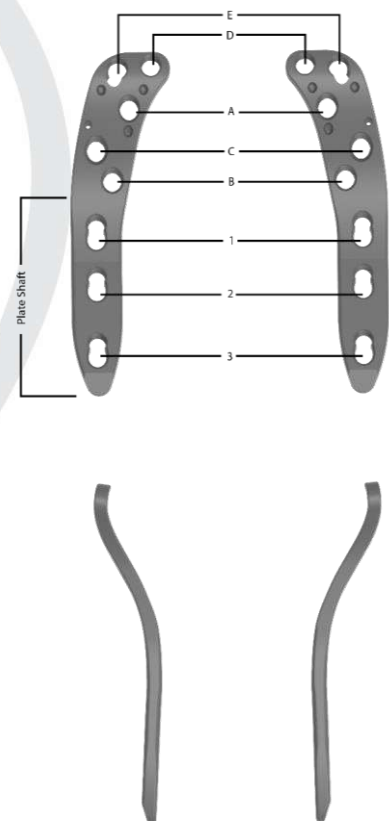



## Step 1: Attach drill guides to the HTO Lateral Plate

**Instruments:**

Ø 4.3 mm Drill Sleeve (Instrument Code: TP245.33)

Thread a 4.3 mm threaded ASLP Drill Guide into an additional proximal plate hole (D or E) as required for the specific surgical procedure. This step concludes the preparation of the HTO Lateral Plate for the insertion of proximal locking screws.



## Step 2: Install spacer

**Instruments:**

5.0 mm Titanium Spacer (Code: ST233)

To complete the assembly, place a 5.0 mm titanium spacer into hole 3 of the HTO Lateral Plate. The spacer provides the necessary separation and support during the surgical procedure.



## Step 3: Determine plate position

**Instruments:**

Ø2.0 mm Guide Pin (Instrument Code:TP245.30)

Following the osteotomy, align the HTO Lateral Plate parallel to the tibial shaft. To temporarily secure the plate, insert the 2.0 mm Guide Sleeve through the 4.3 mm threaded ASLP Drill Guide and introduce the 2.0 mm Kirschner wire. The Kirschner wire aids in determining the screw position and length under the image intensifier.

For detailed osteotomy instructions and precautions, please consult pages 06-10 of this Surgical Technique manual.





## Step 4: Secure HTO Lateral Plate to bone

### Instruments:

Ø 4.3 mm Drill Bit (Instrument Code:TP245.32)  
4.0 N.m. Torque Limiting Screwdriver (Instrument Set:TP245.48)

### Note:

In case the initial screw to be inserted is a locking screw, it is of utmost importance to provisionally stabilize the HTO Lateral Plate firmly on the bone. This precaution prevents simultaneous rotation of the plate and screw during locking, thereby reducing the risk of soft-tissue damage. When it comes to removing the plate, it is strongly advised to manually unlock all screws first before proceeding with their removal. Always employ the 3.5 mm torque limiting screwdriver to securely fasten the locking screws.

Initiate the process by utilizing the calibrated 4.3 mm drill bit to ascertain the suitable screw lengths for holes D and E. To ensure the tibia plateau receives optimal support, insert the longest feasible fixed-angle self-tapping locking screws. Insert an additional self-tapping locking screw into either hole A or C, in accordance with the surgeon's preference.

For the purpose of compressing the osteotomy, insert a 4.5 mm titanium cortex screw into hole 1, angling it distally. Ensure that the spacer remains in position between the HTO Lateral Plate and the periosteum to minimize any potential harm to the blood supply.

Following this, securely affix the shaft portion of the HTO Lateral Plate onto the tibia by introducing a unicortical self-drilling locking screw into hole 2. Replace the spacer in hole 3 with a unicortical self-drilling locking screw. Swap out the cortex screw in hole 1 with a bicortical self-tapping locking screw.

To maximize stability, introduce three locking screws into the proximal section of the osteotomy, ensuring the utilization of all plate holes in the shaft. The initial screw placed in the distal part of the correction should be a bicortical locking screw, whereas unicortical locking screws suffice for the two most distal screws.

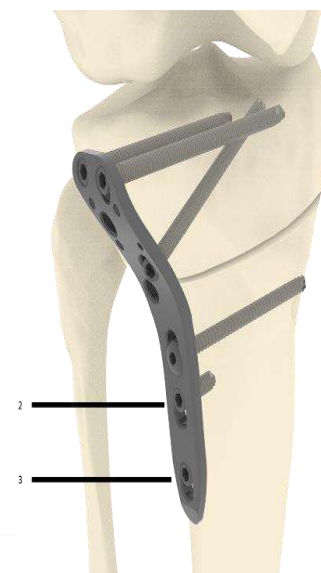
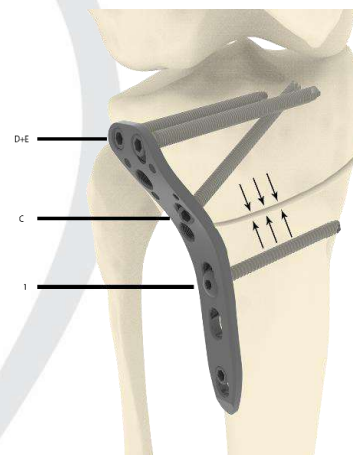
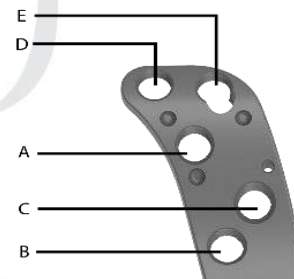



Kindly refrain from employing power tools for tightening the screws, as their maximum torque exceeds the recommended limit, and full power tool tightening could potentially damage the locking screw. Instead, rely on the self-retaining 3.5 mm torque limiting screwdriver for the final tightening. Ensure that the screwdriver is correctly seated within the screw head to avoid any damage to the hexagonal recess of the screw.



**Precaution:**

For the ultimate fastening of all locking screws, use the 3.5 mm torque limiting screwdriver with a 4 Nm torque limit. Do not completely tighten any locking screw using power tools.

**Implant removal:**

Typically, the HTO Lateral Plate does not necessitate removal. If removal is deemed necessary, it should not be undertaken prior to the complete healing of the gap. To initiate the removal of the HTO Lateral Plate, commence by manually loosening all screws and then proceed to remove them with the aid of power tools.





## Surgical Procedure (ASLP-4.5/5.0 Lateral Distal Femur Osteotomy Plate)

### ASLP-4.5/5.0 Lateral Distal Femur Osteotomy Plate

The Lateral Distal Femur Osteotomy Plates are state-of-the-art surgical implants specially designed for lateral distal femur procedures, offering improved features as alternatives to the Lateral Distal Femur Osteotomy Plates. These advanced plates are equipped with features that enhance surgical outcomes and contribute to patient recovery.

Key Features of the Lateral Distal Femur Osteotomy Plates:

**Versatile Combi Holes:** The Lateral Distal Femur Osteotomy Plates incorporate Combi holes in Holes A, B, and 1 through 4. These Combi holes offer surgeons the flexibility to choose between axial compression and fixed-angle locking, allowing for precise adjustments during the surgical procedure.

**Fixed-Angle Locking Holes:** These plates are equipped with specialized locking holes in Holes C, E, F, and G. These holes are designed to accommodate fixed-angle locking screws, ensuring a stable and secure fixation, which is essential for proper bone healing and reducing the risk of post-operative complications.

Manufactured using top-quality materials and advanced design principles, the Lateral Distal Femur Osteotomy Plates offer durability, stability, and excellent surgical performance. Surgeons can confidently employ these plates as superior alternatives to the HTO Plates, leading to improved patient outcomes and facilitating lateral distal femur procedures with increased precision and flexibility.

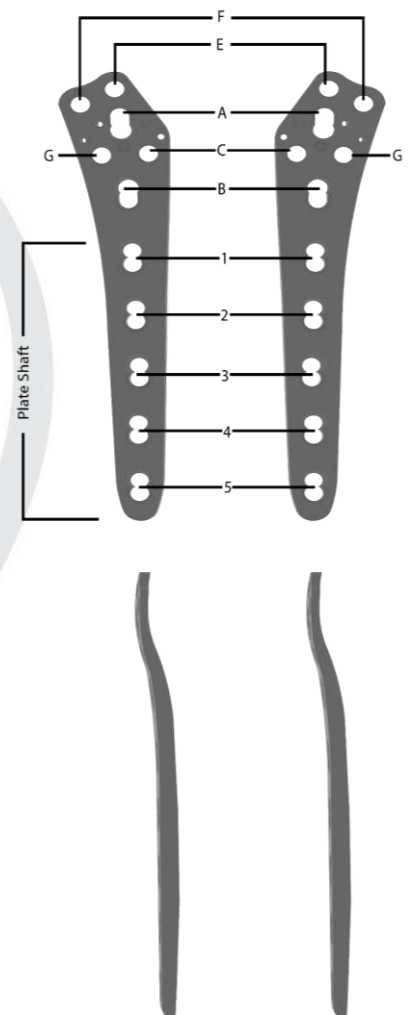



## Step 1: Attach drill guides to the Lateral Distal Femur Osteotomy Plate

**Instruments:**

∅ 4.3 mm Drill Sleeve (Instrument Code: TP245.33)

Insert a 4.3 mm Drill Sleeve Guide into hole A. Securely lock the drill guide.

Thread another 4.3 mm Drill Sleeve Guide into an additional plate hole (F or E) as needed for the specific surgical procedure. This step completes the attachment of the drill guides to the Lateral Distal Femur Osteotomy Plate, facilitating the insertion of screws during the surgical procedure.



## Step 2: Install spacer

**Instruments:**

5.0 mm Titanium Spacer (Code: ST233)

To proceed with the surgical procedure, insert a 5.0 mm titanium spacer into hole 4 of the Lateral Distal Femur Osteotomy Plate. The spacer serves to maintain an adequate distance between the plate and the bone surface, providing support and stability during the procedure.

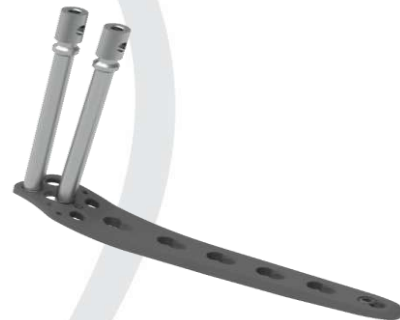

## Step 3: Determine plate position

**Instruments:**

(TP245.34) 2.0 mm Guide Wire Sleeve

Please refer to pages 06-10 of this Surgical Technique for osteotomy instructions and precautions.

After performing the osteotomy, adjust the Lateral Distal Osteotomy Plate parallel to the femoral shaft. To temporarily affix the plate, insert the Guide Sleeve for 2.0 mm Kirschner wires into the 2.0 mm Guide Wire Sleeve, and then insert the 2.0 mm Kirschner wire. The Kirschner wire assists in determining the screw position and length under image intensification, ensuring accurate placement of the Lateral Distal Femur Osteotomy Plate for optimal surgical results.





## Step 4: Secure Lateral Distal Femur Osteotomy Plate to bone

**Instruments:**

(TP245.32) 4.3 mm Drill Bit

(TP245.48) 4.0 N.m. Torque Limiting Screwdriver

**Note:**

In case the first screw to be inserted is a locking screw, it is crucial to provisionally stabilize the Lateral Distal Femur Osteotomy Plate securely on the bone. This precaution prevents simultaneous rotation of the plate and screw during locking, reducing the risk of soft-tissue damage. When removing the plate, it is strongly recommended to manually unlock all screws first and then remove them. Always use the 3.5 mm torque limiting screwdriver to lock the locking screws securely.

Using the calibrated 4.3 mm drill bit, determine the appropriate screw lengths for holes C, E, F, and G, and insert four self-tapping locking screws.

To prevent breaking the far cortex while opening the correction gap, use a cranially ascending lag screw in hole 1.

To secure the shaft portion of the Lateral Distal Femur Osteotomy Plate onto the femur, insert unicortical self-drilling locking screws into holes 2 and 3. Replace the 4.5 mm titanium cortex screw in hole 1 with a bicortical self-tapping locking screw. Remove the spacer in hole 4 and replace it with a unicortical self-drilling locking screw.

For maximum stability, insert four locking screws distal to the correction gap, using all of the plate holes in the shaft. The first screw inserted proximal to the correction must be a bicortical locking screw, while it is sufficient for the three most proximal screws to be unicortical locking screws.

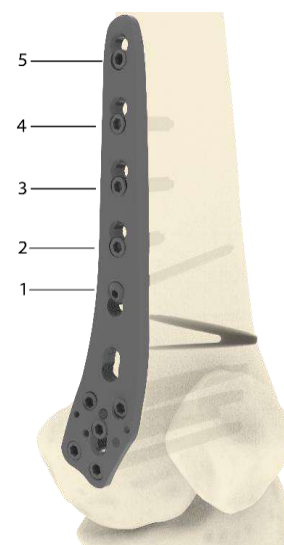
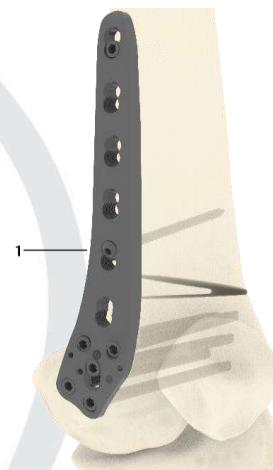
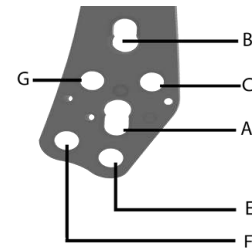



**Precaution:**

Use the 3.5 mm torque limiting screwdriver with a 4 Nm torque limit for the final seating of all locking screws. Do not fully insert any locking screw under power.

**Implant removal:**

In general, the Lateral Distal Femur Osteotomy Plate should not be considered for removal earlier than 12 months following the surgical procedure. To remove the plate, begin by manually loosening all screws, and then proceed to remove them using power tools.





## Implants

### ASLP-4.5/5.0 Medial High Tibia Osteotomy Plate (PT147.04)

The HTO (High Tibial Osteotomy) ASLP-4.5/5.0 Medial High Tibia Osteotomy Plate (PT147.04) is a precontoured implant meticulously crafted to suit the medial proximal tibia. The strategically angled proximal screws contribute to enhanced stability and improved grip on the tibial plate.

Key Features of the HTO Medial High Tibia Plate:

- Robust Midsection for Durability:**  
This plate showcases a sturdy midsection, ensuring it possesses the necessary strength to withstand the forces encountered during the osteotomy procedure. This robust construction significantly enhances the overall stability and longevity of the implant.
- Minimally Invasive Insertion:**  
The tapered end of the HTO Medial High Tibia Plate simplifies minimally invasive insertion, minimizing disruption to surrounding tissues during surgery and promoting quicker recovery.
- Combi Holes for Enhanced Versatility:**  
Incorporating three Combi holes (1, 2, and D), the HTO Medial High Tibia Plate offers versatility to the surgeon, allowing for a choice between axial compression or locking capability as dictated by the surgical needs.
- Locking Screw Compatibility:**  
The plate is designed to accommodate locking screws in Holes 3, 4, A, B, and C. This locking feature ensures a secure and stable fixation, a vital element in achieving successful bone healing and facilitating patient recovery.

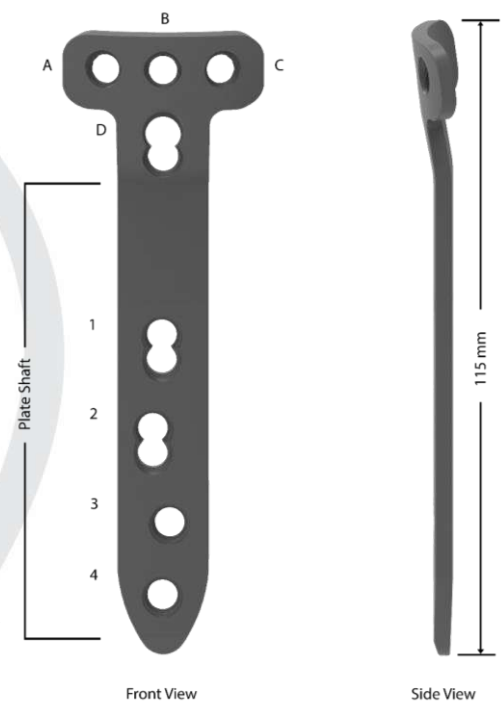

Constructed from commercially pure titanium, a biocompatible material renowned for its strength and safety, the HTO Medial High Tibia Plate guarantees a dependable and secure surgical implant.

With its advanced attributes and sturdy design, the HTO Medial High Tibia Plate represents an exceptional solution for medial high tibial osteotomy procedures, delivering the essential stability and support required for achieving optimal surgical results.



## ASLP-4.5/5.0 Medial High Tibia Osteotomy Plate, small (PT174.04)

The HTO (High Tibial Osteotomy) ASLP-4.5/5.0 Medial High Tibia Osteotomy Plate, small (PT174.04), is a specialized implant tailored for the medial proximal tibia. Its proximal screws are strategically angled to enhance stability and grip on the tibial plate.

Key Features of the HTO ASLP-4.5/5.0 Medial High Tibia Osteotomy Plate, small (PT174.04):

- Precise Precontoured Design:**  
This plate is precontoured to ensure an exact fit on the medial proximal tibia during the surgical procedure, enhancing accuracy.
- Robust Midsection for Durability:**  
The HTO Medial High Tibia Plate boasts a solid midsection, imparting the requisite strength to withstand the osteotomy and the forces encountered during the procedure. This robust design significantly bolsters the implant's overall stability.
- Minimally Invasive Insertion:**  
The tapered end of the HTO Medial High Tibia Plate eases minimally invasive insertion, reducing tissue disruption during surgery and facilitating faster patient recovery.
- Combi Holes for Enhanced Versatility:**  
Strategically integrated are three Combi holes (1, 2, and D), offering surgical flexibility, allowing for a choice between axial compression or locking capability as per the surgical demands.
- Locking Screw Compatibility:**  
The plate is configured to accommodate locking screws in Holes 3, 4, A, B, and C, ensuring secure and stable fixation, vital for successful bone healing and patient recovery.

Constructed from commercially pure titanium, a biocompatible material renowned for its strength and biocompatibility, the HTO ASLP-4.5/5.0 Medial High Tibia Osteotomy Plate, small (PT174.04) ensures a dependable and safe surgical implant.

With its advanced attributes and precision design, the ASLP-4.5/5.0 Medial High Tibia Osteotomy Plate, small (PT174.04) presents an exceptional solution for medial high tibial osteotomy procedures, providing the required stability and support to achieve optimal surgical outcomes, fostering successful bone healing, and facilitating patient recovery.

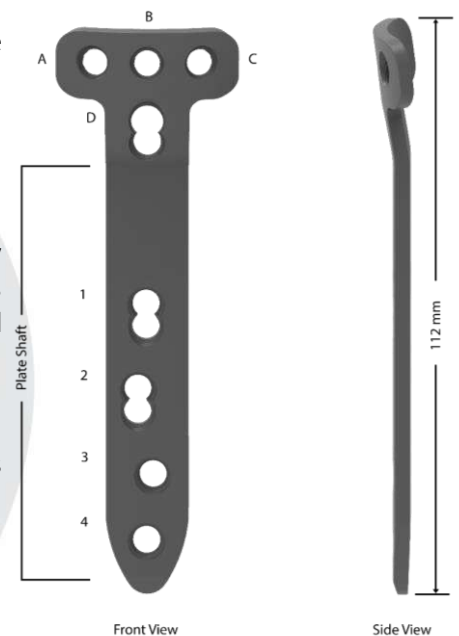



## ASLP-4.5/5.0 Lateral High Tibia Osteotomy Plate Right & Left (PT148.03.01& PT148.03.02)

The ASLP-4.5/5.0 Lateral High Tibia Osteotomy Plate, available in both Right (PT148.03.01) and Left (PT148.03.01) configurations, are meticulously shaped to match the lateral proximal tibia's anatomy. Their thickness, ranging from 3.1 mm to 4.5 mm, ensures the necessary strength for supporting the osteotomy without causing irritation to the surrounding soft tissues. Moreover, the tapered end of the plate streamlines minimally invasive insertion, thereby enhancing patient comfort and expediting the recovery process.

### Key Features of the HTO Lateral High Tibia Plates:

- **Versatile Screw Options:** Hole E in the plate is designed to accept both 4.5 mm titanium cortex screws and 5.0 mm locking head screws. Holes A, B, C, and D are tailored to accommodate fixed-angle 5.0 mm locking head screws. This versatility empowers the surgeon to choose the most suitable fixation method tailored to each patient's unique requirements.
- **Combi Holes for Enhanced Flexibility:** The shaft of the HTO Lateral High Tibia Plate integrates three Combi holes, offering the surgeon flexibility in employing axial compression or fixed-angle locking, thereby ensuring precise adjustments during the surgical procedure. This adaptability is instrumental in achieving optimal surgical outcomes.
- **High-Quality Material:** The HTO Lateral High Tibia Plates are expertly crafted from Ti-6Al-4V, a high-quality titanium alloy known for its biocompatibility, robustness, and resistance to corrosion. This choice of material ensures reliable implant performance and compatibility with the patient's body.

With their precontoured design, versatile screw options, and high-quality construction, the HTO Lateral High Tibia Plates serve as outstanding solutions for lateral high tibial osteotomy procedures. These plates deliver the requisite stability and support to facilitate successful bone healing, empowering patients to resume their daily activities with improved joint function and reduced discomfort.

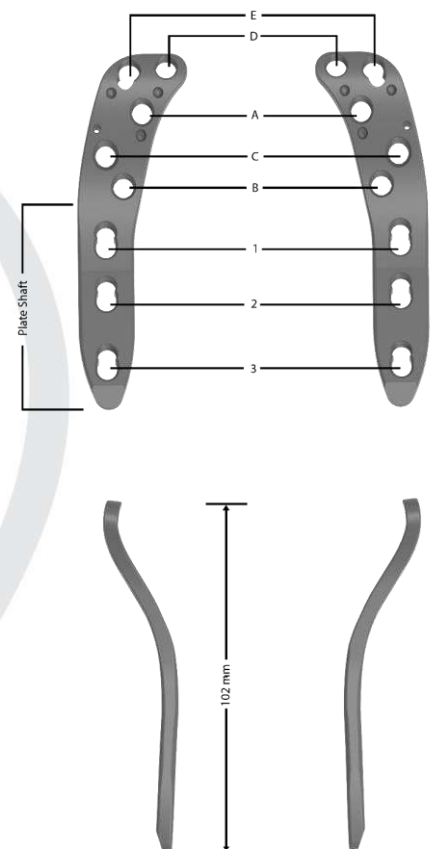



## ASLP-4.5/5.0 Lateral Distal Femur Osteotomy Plate, Right & Left (PT175.04.01 & PT175.04.02)

The ASLP-4.5/5.0 Lateral Distal Femur Osteotomy Plate, available in both Right (PT175.04.01) and Left (PT175.04.02) configurations, are meticulously crafted to conform to the anatomical characteristics of the lateral distal femur. The precontoured shape of these plates ensures a precise fit during surgical procedures, facilitating optimal outcomes. Furthermore, the plates' tapered end streamlines minimally invasive insertion, minimizing tissue disruption and fostering accelerated patient recovery.

Key Features of the Lateral Distal Femur Osteotomy Plates:

- **Combi Holes for Enhanced Versatility:** The plates incorporate Combi holes in Holes A, B, and 1 through 4. These Combi holes grant the surgeon the flexibility to choose between axial compression or fixed-angle locking, based on the specific requirements of the patient and the surgical procedure.
- **Fixed-Angle Locking Holes:** The plates are equipped with fixed-angle locking holes in Holes C, E, F, and G. These dedicated holes are designed to accommodate fixed-angle locking screws, ensuring a secure and stable fixation to promote proper bone healing and patient recovery.
- **High-Quality Material:** The Lateral Distal Femur Osteotomy Plates are constructed using Ti-6Al-4V, a premium titanium alloy renowned for its biocompatibility, robustness, and resistance to corrosion. This choice of material guarantees dependable implant performance and compatibility with the patient's body.

With their precontoured design, versatile hole options, and high-quality construction, the Lateral Distal Femur Osteotomy Plates are excellent choices for lateral distal femur procedures. These plates provide the requisite stability and support to facilitate successful bone healing, thus promoting a smoother recovery process and improved joint function for the patient.

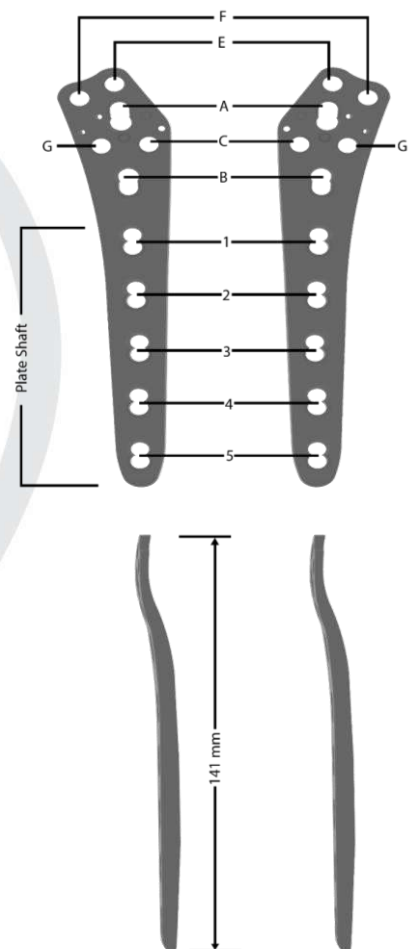



ASLP-4.5/5.0 Medial Distal Femur 20° Osteotomy Plate,  
Right & Left (PT176.20.04.01 & PT176.20.04.02)

ASLP-4.5/5.0 Medial Distal Femur 29° Osteotomy Plate  
(PT176.29.04.01 & PT176.29.04.02)

The Medial Distal Femur Osteotomy Plates, available in both left and right configurations, have been meticulously crafted with precontoured precision to perfectly match the anatomical nuances of the medial distal femur. This design ensures a seamless and precise fit during surgical procedures, ultimately optimizing stability and providing vital support for the proper healing of bone tissue.

Key Features of the Medial Distal Femur Osteotomy Plates:

- **Tapered End for Ease of Insertion:** These plates feature a tapered end, allowing for smooth and minimally invasive insertion. This thoughtful design minimizes tissue disruption during surgery, leading to a more comfortable recovery for the patient.
- **Combi Holes for Enhanced Versatility:** The plates incorporate Combi holes, affording the surgeon the flexibility to choose between axial compression or locking capability. These versatile hole options enable precise adjustments during the surgical procedure, ensuring optimal outcomes.
- **Fixed-Angle Locking Holes:** The plates also include fixed-angle locking holes, allowing for the use of multiple fixed-angle constructs throughout the plate. This feature enhances the retention of screws in both the plate and cortical bone, further promoting stability and supporting successful bone healing.
- **High-Quality Material:** The Medial Distal Femur Osteotomy Plates are constructed from commercially pure titanium, recognized for its biocompatibility and strength. This ensures the reliability and safety of the surgical implant, making it highly suitable for use in orthopedic procedures.

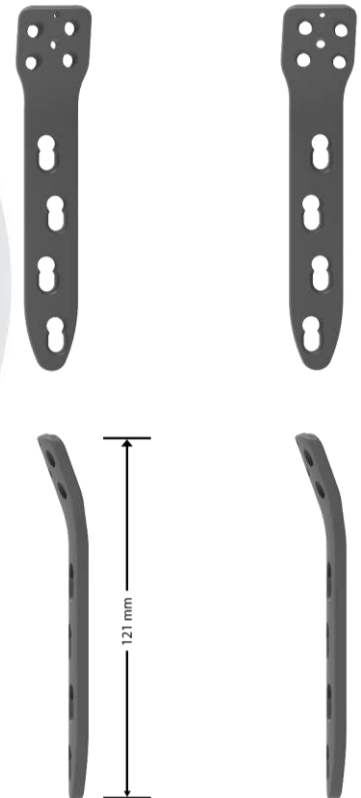

With their precontoured design, versatile hole options, and high-quality construction, the Medial Distal Femur Osteotomy Plates are excellent choices for medial distal femur procedures. These plates provide the essential stability and support necessary for successful bone healing, ultimately resulting in improved joint function for the patient.

**Please note that the product codes (PT176.20.04.01 & PT176.20.04.02) & (PT176.29.04.01 & PT176.29.04.02) should remain unchanged to ensure proper identification and ordering of the correct plate configurations.**



## Implants

### ASLP – 4.5/5.0 Medial High Tibia Osteotomy Plate Small

Titanium	Holes	Length(mm)
PT174.04	4	112



### ASLP – 4.5/5.0 Medial High Tibia Osteotomy Plate

Titanium	Holes	Length(mm)
PT147.04	4	115



### ASLP – 4.5/5.0 Lateral Distal Femur Osteotomy Plate

Titanium	Holes	Right/Left	Length(mm)
PT175.04.01	4	Right	141
PT175.04.02	4	Left	141



### ASLP – 4.5/5.0 20 ° Medial Distal Femur Osteotomy Plate

Titanium	Holes	Right/Left	Length(mm)
PT176.20.04.01	4	Right	121
PT176.20.04.02	4	Left	121



### ASLP – 4.5/5.0 29 ° Medial Distal Femur Osteotomy Plate

Titanium	Holes	Right/Left	Length(mm)
PT176.29.04.01	4	Right	121
PT176.29.04.02	4	Left	121



### ASLP – 4.5/5.0 Lateral High Tibia Osteotomy Plate

Titanium	Holes	Right/Left	Length(mm)
PT148.03.01	3	Right	104
PT148.03.02	3	Left	104





## Instruments

1. TP245.24 Osteotomy chisel 10 mm



2. TP245.25 Osteotomy chisel 15 mm



3. TP245.26 Osteotomy chisel 20 mm



4. TP245.27 Osteotomy chisel 25 mm



5. TP245.28 Ø 2.5 mm guide pin



6. TP245.29 Ø 2.5 mm guide pin with drill bit



7. TP245.30 Ø 2.0 mm guide pin



8. TP245.31 Ø 3.2mm drill bit



9. TP245.32 Ø 4.3mm drill bit



10. TP245.33 Ø 4.3mm drill sleeve



11. TP245.34 Ø 2.0mm guide wire sleeve



12. TP245.35 SW3.5 shaft





13. TP245.36 Tap HC Ø5.0



14. TP245.37 Alignment rod



15. TP245.38 4.5/5.0 universal drill sleeve with  
4.3mm drill bit



16. TP245.39 Stand for alignment rod ( Large )



17. TP245.40 Stand for alignment rod ( Small )



18. TP245.41 Caliper





19. TP245.42 Straight quick coupling handle



20. TP245.43 Osteotomy Gap measuring device



21. TP245.44 Osteotomy angle measuring Guide



22. TP245.45 Depth gauge



23. TP245.46 Stand for alignment rod ( Straight )



24. TP245.47 Distracting forceps self locking



25. TP245.48 4.0 Nm torque limiting handle





Instruments Set

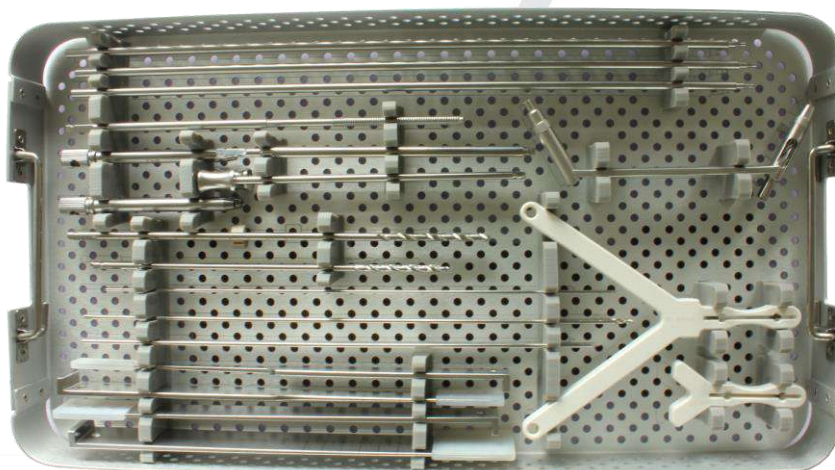
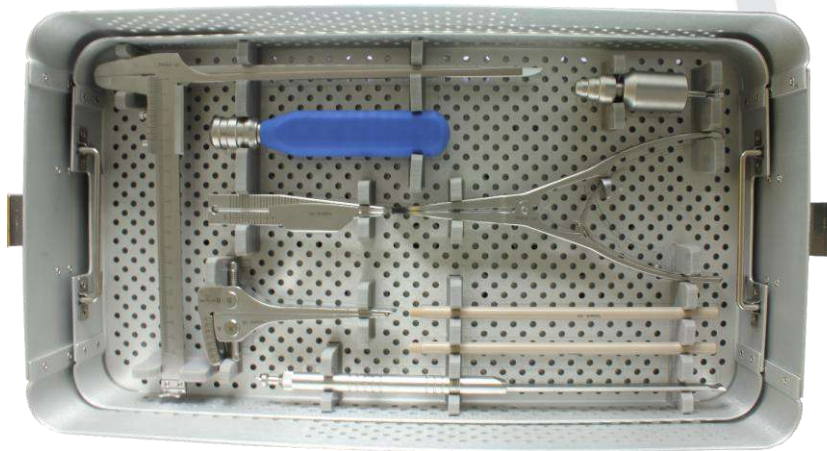
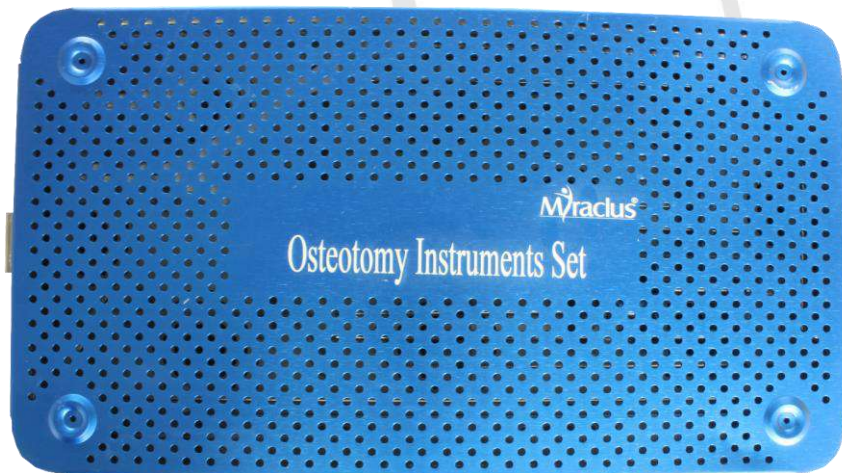



## Miraclus Orthotech Pvt. Ltd.

Phone : +91 79 2583 1332, 2583 1333  
Email : [contact@miraclus.com](mailto:contact@miraclus.com) | [www.miraclus.com](http://www.miraclus.com)

**Plant -II :**  
Survey No. 106, Village Vavdi, Opp. Safex Industries,  
Behind Elite Boarding School, Vavdi,  
Ta. Kheda-387550, Gujarat, India